



## Analysis of flow characteristics of TiO<sub>2</sub>-water nanofluid under magnetic field effect

Murat Erdem<sup>1</sup>, Yasin Varol<sup>2</sup>

<sup>1</sup> Technical Vocational School, Firat University, 23119, Elazig, Turkey

<sup>2</sup> Department of Automotive Engineering, Technology Faculty, Firat University, 23119, Elazig, Turkey

Adding nanoparticles to the basic fluid and applying an external magnetic field to the duct, which is one of the techniques to increase heat transfer in recent years, is one of the frequently studied topics in the literature. In this study, the velocity and pressure changes of TiO<sub>2</sub>-water nanofluid under the influence of magnetic field have been numerically investigated. The numerical study has been carried out with ANSYS-Fluent commercial software. The study was analyzed for various Ha, nanofluid volume ratios, and Re numbers. It was concluded that the nanofluid velocity decreased with both nanoparticle and magnetic field, but the pressure increased with these two parameters.

**Keywords:** Nanofluid, Magnetic field, Forced convection.

Submission Date: 15 February 2022

Acceptance Date: 03 May 2022

\*Corresponding author: [yvarol@gmail.com](mailto:yvarol@gmail.com)

### 1. Introduction

In many technical applications such as solar collectors, heat exchanger, power plants, high-performance boilers, cooling systems, and chemical catalytic reactors, forced convection in any channel is one of the essential subjects [1 - 5]. One of the most important subjects of engineering science is the control of nano fluid motion by a magnetic field. In relation to fluids with suspended nano particles, Choi [6] is the first scholar to use the term nanofluids. Some studies [1,7,8,9] have shown that thermal conductivity can be increased by about 20 percent with low concentrations of nano particles by motion the flow characteristics. Similarly, Hartmann [10] performed the first report on MHD. Hartmann studied the action of an incompressible viscous and electrically conductive fluid under a magnetic field between two parallel plates.

A lot of work has been done on this subject by several researchers [11-15]. The works of some of them are listed as follows.

In a microtube with continuous heat flux, Salman et al. [16] numerically studied flow characteristics of different nanofluids consisting of ethylene glycol-Al<sub>2</sub>O<sub>3</sub>, ZnO, CuO, SiO<sub>2</sub> at 1-4 percent volume fraction. In a sudden expansion tube with constant wall temperature, Kimouche et al. [17] numerically examined turbulent forced convection nanofluids, Cu-water, CuO-water, Al<sub>2</sub>O<sub>3</sub>-water at a volume fraction of 2-20 percent. Sheikholeslami et al. [18] numerically investigated the flow characteristic and natural convective heat transfer using the Lattice Boltzmann Method (LBM) in a semi-channel filled with a nanofluid composed of Al<sub>2</sub>O<sub>3</sub>-water under magnetic field intensity. Hatemi et al. [19] investigated the convective heat transfer phenomena of a nanofluid flow consisting of Al<sub>2</sub>O<sub>3</sub>-water on a flexible horizontal plate using the Homotopy Analysis Method (HAM) and numerical procedure to assess the flow characteristics and heat transfer as MHD functions and the volume fraction of nanoparticles. In a pipe under magnetic field, Erdem and Varol [20], Erdem [21], Erdem et al. [22], and Erdem and Varol [23] examined in detail Cu-water, some different nanoparticles, lithium liquid and PbLi<sup>17</sup> liquid in terms of flow behavior and heat transfer, respectively. Mishra and Kumar [24] investigated magnetohydrodynamic

(MHD) silver-water ( $\text{Ag}/\text{H}_2\text{O}$ ) flow and heat properties. Some of the results of the research are the magnetic parameter and the effects of thermal drift to reduce velocity profiles.

The purpose of this work is to investigate numerically MHD forced convection flow characteristics for  $\text{TiO}_2$ -water nanofluid in a three-dimensional circular channel under the magnetic field. The selected nanoparticle volume-fraction and  $\text{Ha}$  numbers are 0, 0.01, 0.03, 0.05 and 25, 50 and 100, respectively. The magnetic field has applied perpendicular to the flow direction at the outside of the channel. The nanofluid input temperature is bigger than the temperature of the wall. In particular, the results related to the change in fluid characteristics with the addition of nanoparticles are a matter of curiosity for researchers. Therefore, in the study, it is recommended to carry out new analyzes for flow motion and efficiency of energy systems with different geometries, different boundary conditions and different methods.

## 2. Numerical Modelling

The pipe model used in this numerical model is shown in Fig. 1. The analysis was planned by ANSYS-WORKBENCH and analyzed by means of the commercial program ANSYS-FLUENT. It is a cylindrical pipe having area with (D) mm diameter and L (mm) length and has been exposed to perpendicularly external magnetic field. The fluid enters the channel at a certain velocity and temperature.

The temperature of the nanofluid entering the cylindrical channel is higher than the temperature of the pipe wall, so the fluid is under cooling conditions.

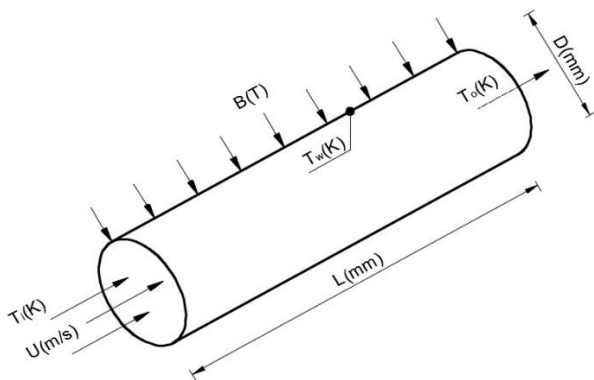
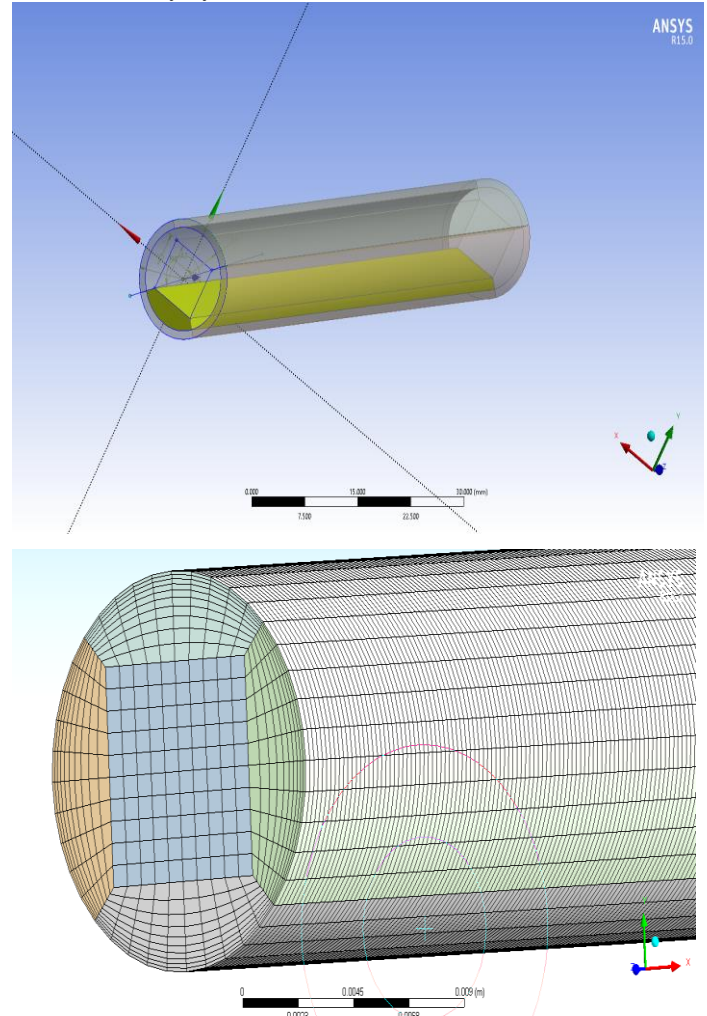

**Figure 1.** 3D circular channel model [22].

Fluid inlet temperature ( $T_i$ ) and wall temperature ( $T_w$ ) was kept constant at different temperature. Inlet temperature and wall temperature are  $50^\circ\text{C}$  and  $30^\circ\text{C}$ , respectively. Thermo-physical properties were selected according to this temperature value. Thermo-physical values are taken from Ref. [21].

The divided pipe model and mesh type created for this numerical study is presented in Fig. 2. As seen in the figure, the model is divided into 5 different solid parts. For the pipe geometry, making the mesh structure in this way is very important in terms of giving correct results. The Orthogonal

quality and Aspect ratio obtained by this method is 0.965 and 5.72, respectively. Mesh values in this study are quite good values according to the literature. In the literature, due to the difficulties in the application of this method in general, the solid model is created as a single piece. This may not always give the exact result. When the model is a single piece, such a clear mesh cannot be made. To see this difference in more detail, the study by Erdem [21] can be examined.



**Figure 2.** Divided pipe model and mesh structure

The calculations used for this study are as follows.

With ANSYS Fluent commercial program, the numerical analysis was performed. This research uses the finite volume technique to solve the governing equations. For pressure-velocity coupling, the SIMPLE algorithm was adopted. The nanofluid in the pipe was been used as a laminar, incompressible single-phase Newtonian flow model. Here, since the nano particles are too small, the nano fluid serves as a single phase.

The dimensioned Navier-Stokes equations is calculated as follows [25,26]:

$$\nabla \cdot \vec{V} = 0 \quad (1)$$

$$(\vec{V} \cdot \nabla) \vec{V} = -\frac{1}{\rho_{nf}} \nabla P + \nu_{nf} \nabla^2 \vec{V} + \frac{1}{\rho_{nf}} \vec{F} \quad (2)$$

$$(\vec{V} \cdot \nabla) \vec{T} = \alpha_{nf} \nabla^2 \vec{T} \quad (3)$$

$\vec{F}$ , the buoyancy force and the body force resulting from the Lorentz forces are expressed as [25, 27]:

$$\vec{F} = \vec{J} \times \vec{B} \quad (4)$$

The final term is defined in Equation (4) as the Lorentz force, which causes fluid motion.

$\vec{J}$ , electric current density is defined by the Ohm law:

$$\vec{J} = \rho_{nf} (\vec{E} + \vec{V} \times \vec{B}) \quad (5)$$

$\vec{E}$ , is the DC electrical current and  $\vec{B}$ , is magnetic field in the z direction. The magnetic field and the electrical current are thus perpendicular to each other, creating the x- and y-directions of the Lorentz power.

Thermo-physical properties of fluid and nanoparticles were taken from Ref. [21]. Thermo-physical properties of nano-fluid at reference temperature of  $T_i = 50 \text{ }^\circ\text{C}$  are taken from ( $T_w = 30 \text{ }^\circ\text{C}$ ):

Nano-fluids density is calculated from the following equation:

$$\rho_{nf} = (1 - \phi) \rho_f + \phi \rho_s \quad (6)$$

The specific heat capacity of nanofluid is found from the following equation:

$$(\rho c_p)_{nf} = (1 - \phi) (\rho c_p)_f + \phi (\rho c_p)_s \quad (7)$$

Heat conductivity of nanofluid ( $k_{nf}$ ) is computed from the following equation:

$$\frac{k_{nf0}}{k_f} = \frac{k_s + 2k_f - 2\phi(k_f - k_s)}{k_s + 2k_f + \phi(k_f - k_s)} \quad (8)$$

Eq. (9) and (10) are used to calculate nano-fluid dynamic viscosity and Ha number.

$$\mu_{nf} = \frac{\mu_f}{(1 - \phi)^{2.5}} \quad (9)$$

$$Ha = B_0 R \sqrt{\frac{\sigma_{nf}}{\rho_{nf} \nu_f}} \quad (10)$$

### 3. Results and Discussion

Pipe diameter flow rate, pipe center pressure variations are presented comprehensively on graphs. In the results, it was aimed to better understand the effect of magnetic field, nanoscale ratio and Re number by showing them separately. The comparisons of fluid velocities along the pipe diameter of the magnetic field strength at various Re numbers and nano volumetric ratios are shown in Fig. 3. Results are presented for five different Re numbers and three different nano-volumetric ratios. Re numbers and nano-volumetric ratios were chosen as  $Re = 10, 100, 500, 1000, 2000$  and  $\phi = 0.01, 0.03, 0.05$ , respectively. Hartmann numbers are taken as  $Ha = 0, 25, 50$  and  $100$ . Here, it has been discussed that what kind of change occurs in the motion of the fluid under laminar conditions, both when passing from low Re number to high Re number and by the effect of nanoparticle. Here, each graph has determined the velocity changes occurring in the pipe diameter in the absence and presence of magnetic field effect. As expected, a large increase in velocities was observed with the increase in the Re number. In addition, it is seen that as the Re number increases, the velocity curves change from parabolic state to flat state, that is, the irregularity of the flow increases.

For all graphs, it is clearly seen that the magnetic field strength applied to the channel from the outside significantly reduces the fluid velocity. The drop in fluid velocity is greater than the drop caused by the addition of nanoparticle. The reason for these decreases in fluid velocity with the magnetic field is due to the retarding effect of the Lorentz force. In all graphs, when magnetic field is applied, it is understood that the decrease in velocities is much greater than when there is no magnetic field, but when under magnetic field ( $Ha = 25-100$ ), the velocity drop that occurs

with the increase of this field is less. All velocity profiles from the figure showed the same trend. Fig. 4 represents the analysis of the nanofluid volumetric ratio within each graph at different Re and Ha numbers for the TiO<sub>2</sub>-water nanofluid. The figure shows the analysis results between Re = 10 - 2000 from the first row to the last row and Ha = 0 - 100 from the first to the last column. In the previous figure, it was stated that the fluid velocity of nano fluids at all rates is lower than the velocity of the base fluid. Therefore, pure water curve, which is the basic fluid, has not been considered again here. Only the changes between  $\phi = 0.01$  - 0.05 were analyzed in each graph to better understand the state of nanofluid rates relative to each other. Unlike some

studies in the literature, there is no sudden peak event that rises above the curves in the middle of the channel. Especially, it is striking that the fluid that throws a small peak at Re = 10 belongs to the basic fluid, water. This result can also be related to the density of the fluid. Here, increased density or even changed thermo-physical properties with the addition of nanoparticles may have been effective. At the same time, the preferred mesh structure has also been effective in achieving such smooth results. It is understood from the figures that the speed of the nanofluid decreases as the nano-volume ratio increases.

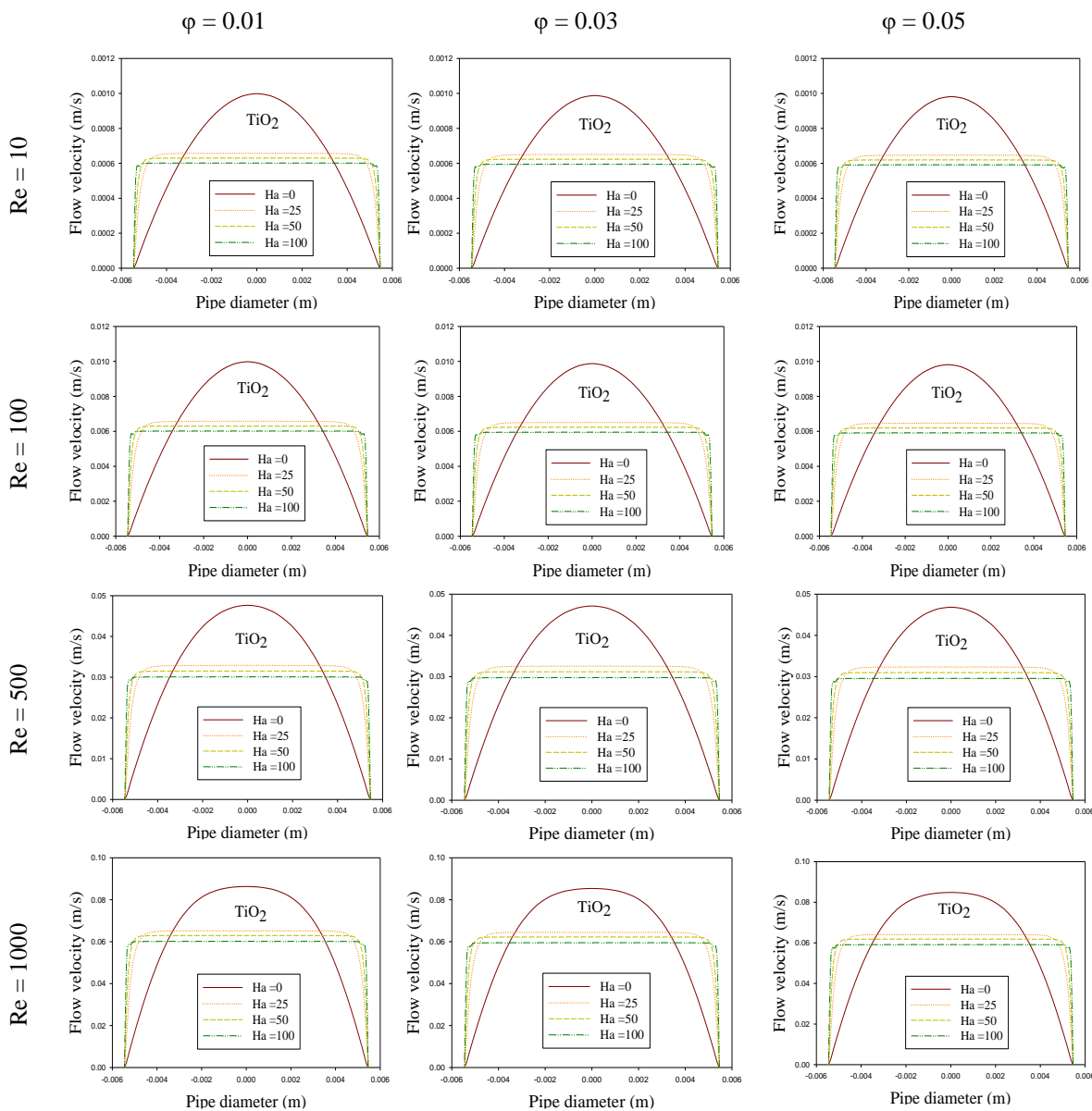

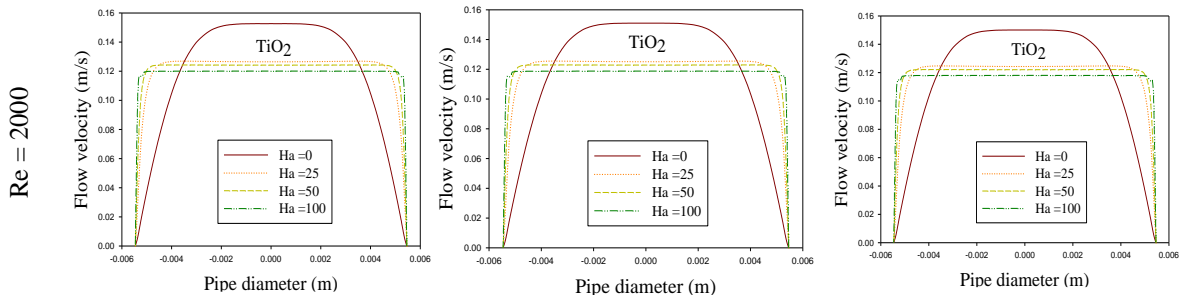

**Figure 3.** TiO<sub>2</sub>-water nano fluid velocity changes in the pipe diameter by applying magnetic field forces at various Re values and nano-volumetric ratios.

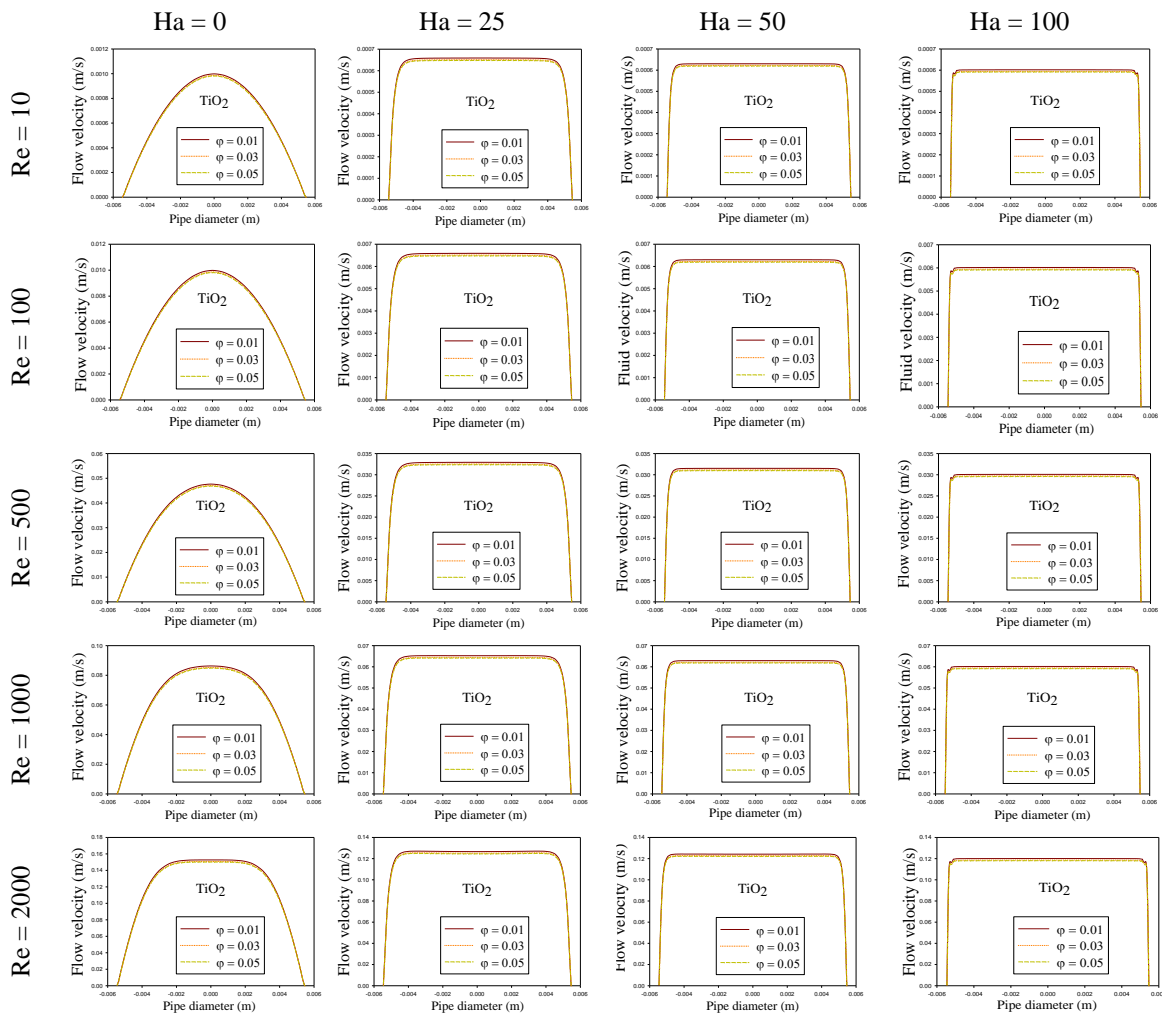

**Figure 4.** Comparison of the volumetric ratios of TiO<sub>2</sub> Nano fluid at different Re numbers and Ha numbers

The diameter and Re changes of fluid velocity in various nano-volumetric ratio and magnetic field strengths for TiO<sub>2</sub> are shown in Fig. 5. In these figures, the change of Re number with the pipe diameter can be seen more clearly on the same graph. It is clearly understood from all the graphs in the figure that the fluid velocities increase a lot with the

increase of Re number. In this figure, it is determined that the velocity values for Re = 10 are close to zero and the velocity values increase proportionally with the increase of Re number. When the lines in the figure are examined, it is understood from the figure scales that the velocities decrease with the increase of Ha values.

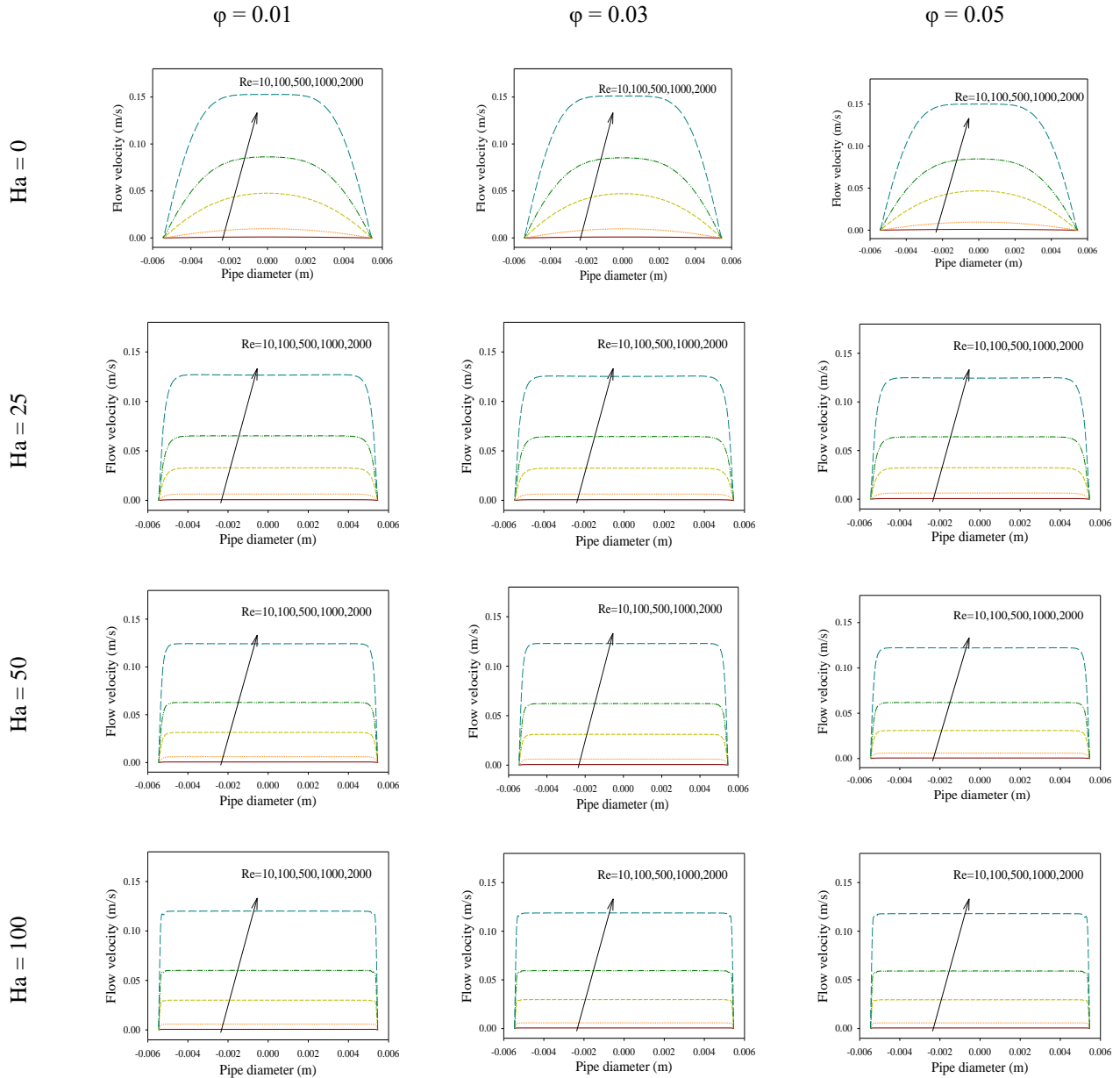

**Figure 5.**  $TiO_2$ -water nanofluid diameter velocity changes with  $Re$  for various volumetric ratios and magnetic field strengths.

Fig. 6 represents the pressure changes in the center of the channel containing  $TiO_2$  - water nanofluid. Here, each graph presents comparisons of different  $Ha$  numbers at constant  $Re$  number and nano-volume ratios. In all graphs it is clear that the application of magnetic field strength causes a large increase in pressures along the center of the circular channel. When the figure is examined, there has been an increase in the pressure values both due to the increase in the number of  $Re$  from top to bottom and the increase in the ratio of nanoparticles from left to right. However, it was determined that the pressure difference caused by the increase in  $Re$  number is much greater. In

addition, it can be understood from the scales of the Graphs that the pressure values increase with the effect of nanoparticles. Pressure variations in various nano-volumetric ratios of  $TiO_2$  - water nano fluid in different  $Re$  numbers and magnetic field strength are depicted in Fig. 7. The increase in pressures with the doubling of  $Re$  numbers and increasing magnetic field strength is very high. The Fig. 7 shows that when the magnetic field intensity is not applied, the pressure curves in the graph have become parabolic from flat with the increase of  $Re$  number and these curves become flat with the increase of both  $Ha$  and  $Re$  numbers.

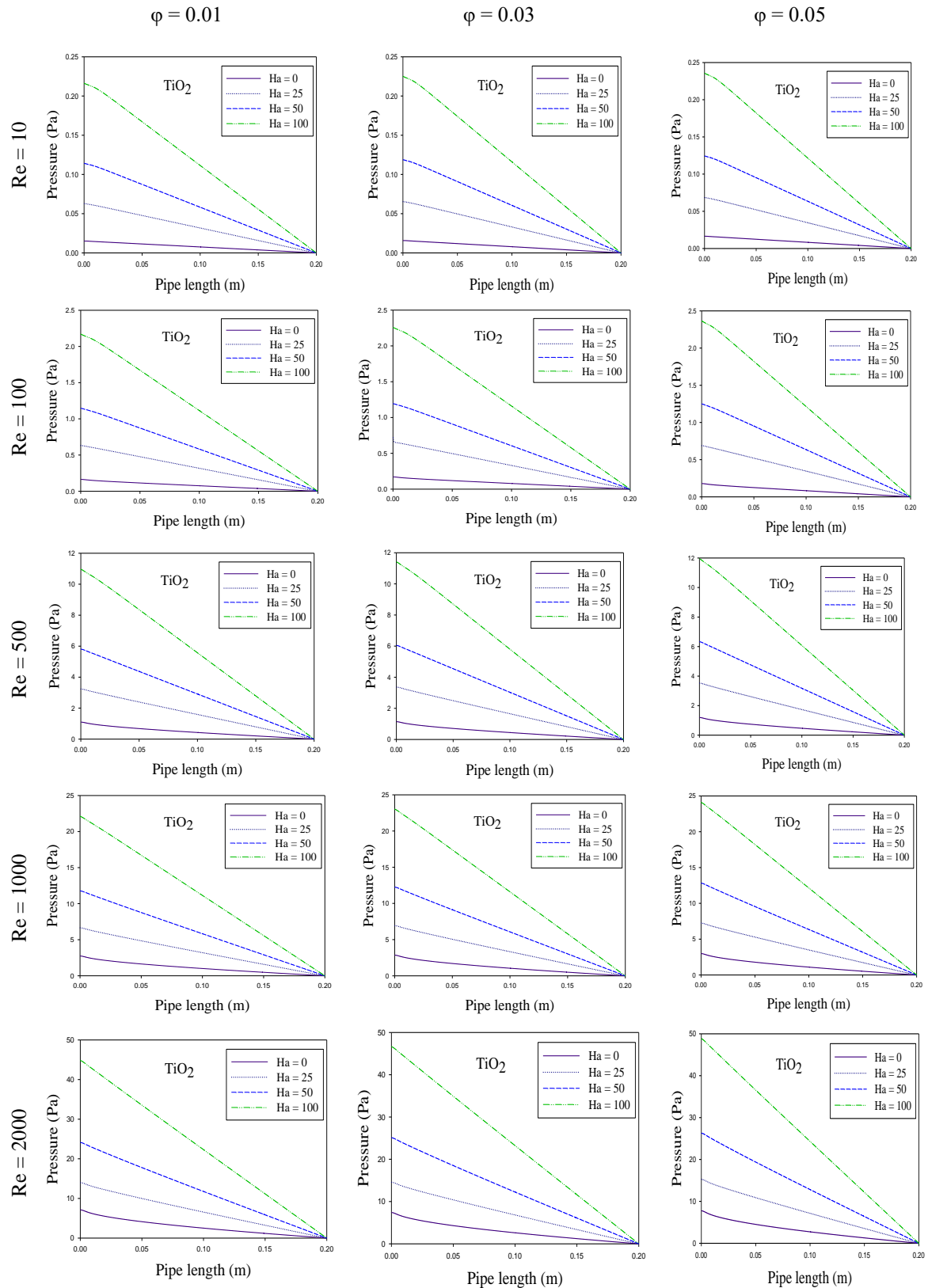

**Figure 6.** Variation of the center pressure values of the  $TiO_2$ -water nanofluid with  $Ha$  number at various  $Re$  and nano-volumetric ratios.

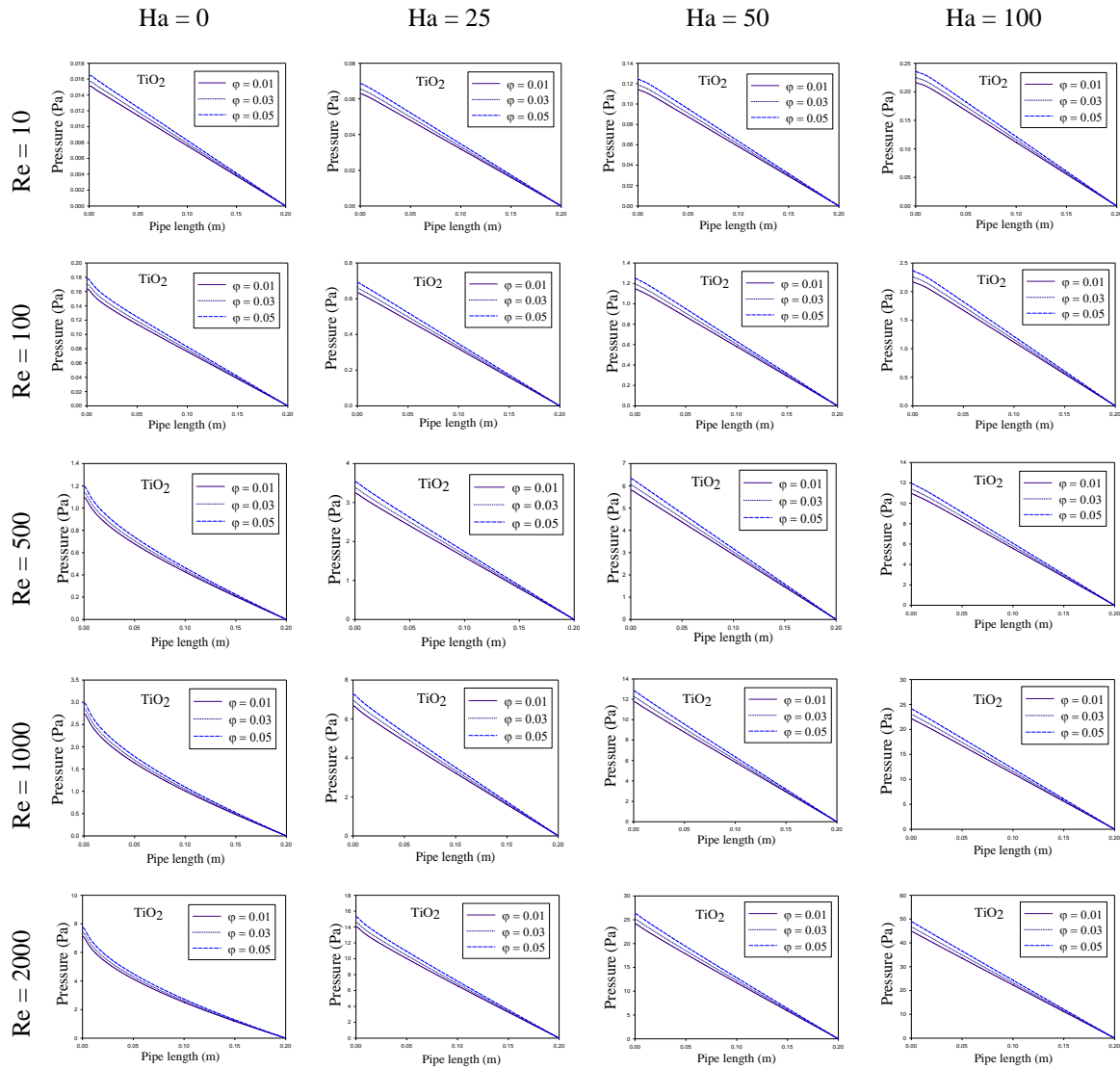

**Figure 7.** Comparison of the volumetric ratios of  $TiO_2$ -water nanofluid at different  $Re$  numbers and magnetic field strength.

Figure 8 shows the pressure analysis for the  $Re$  effect of  $TiO_2$  - water nanofluid at four different magnetic field strengths and three different nano-volumetric ratios. When each line in the figure is examined separately, the effect of the change in the pressure curves with the  $Re$  effect is

clearly seen. Here, pressure values have increased largely due to fluid transport. When we look at the first lines in the graphs, it is better seen that the curves are more parabolic. This curve has become more parabolic with the increase of  $Re$  in the same row.

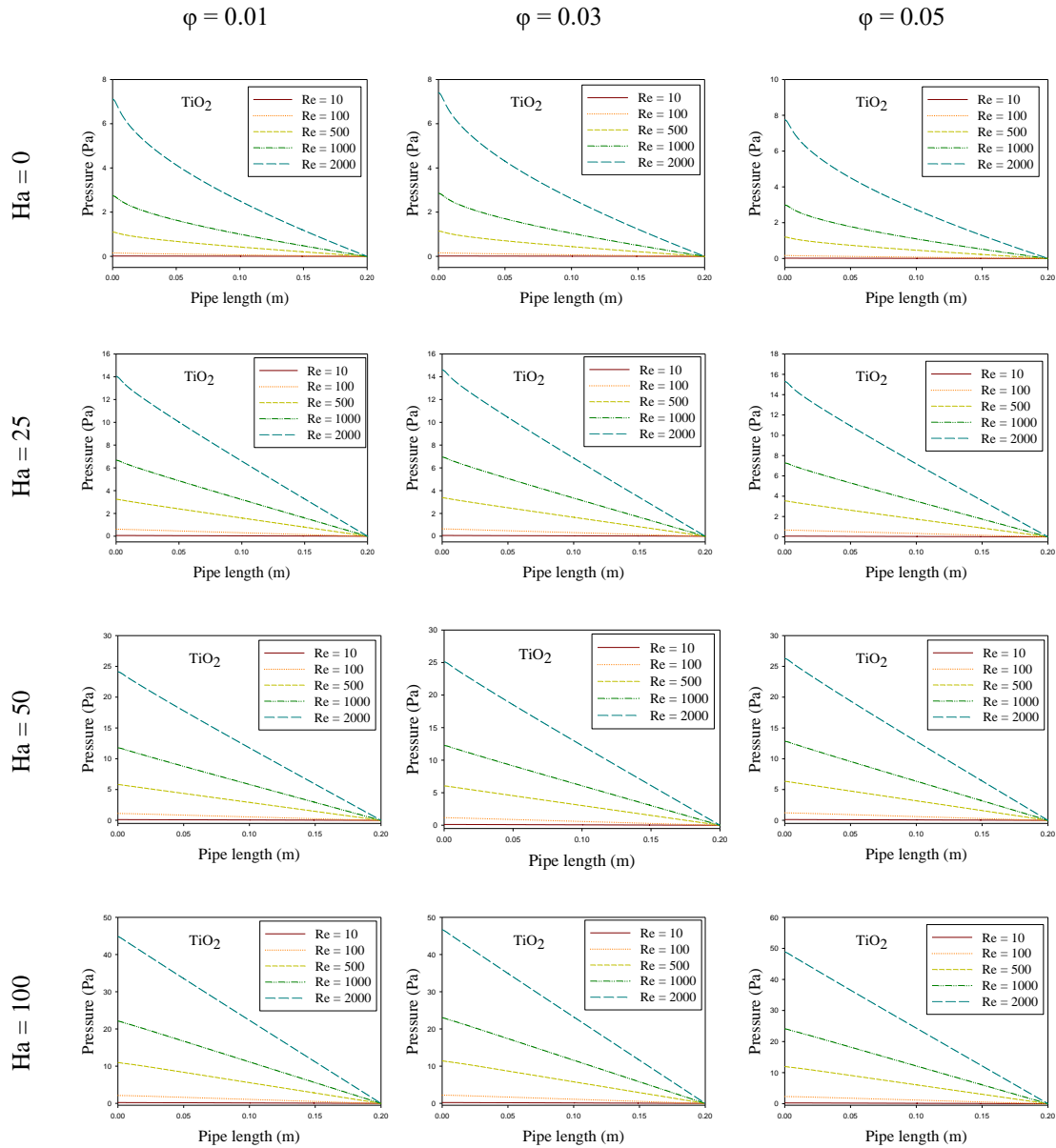

**Figure 8.** Variation of Re number on center pressure for TiO<sub>2</sub>-water nanofluid

In fact, Fig. 6, 7, and 8 are identical, depicting them in three different Figures will result in a much clearer understanding of the effects of these variables (Re, Ha, and the nanoscale ratio) on pressure. Therefore, it was concluded which parameter is more effective. The results obtained here are in agreement with the literature [28].

#### 4. Conclusion

In this study, the numerical analysis of TiO<sub>2</sub>-water-nanofluid flowing in a pipe under cooling conditions has been investigated in terms of flow characteristics. Analyzes have been performed for different Re, Ha and nano volume ratio. Results obtained for fluid velocity and pressure have been comprehensively obtained and presented. The results found are presented in detail below:

- ✚ The external magnetic field force applied to the channel significantly reduced the fluid velocity.
- ✚ Fluid velocity decreased with the addition of nanoparticles.
- ✚ The fluid velocity drop caused by the magnetic field is greater than the drop caused by the addition of nanoparticles.
- ✚ With both the magnetic field and the nanoparticle, the pressure of fluid has increased across the center of the pipe.

As a result, the motion of the nanofluids can be kept under control by the magnetic field strength.

## Acknowledgement

The authors thank to Firat University Scientific Research Project (FUBAP) due to their support to numbered TEKF.15.01 project.

## References

- Heidary H, Hosseini R, Pirmohammadi M, Kermani MJ. Numerical study of magnetic field effect on nano-fluid forced convection in a channel. *J magn magn Mater.* 2015;374:11-7.
- Wang BX, Du JH, Peng, XF. Internal natural, forced and mixed convection in fluid-saturated porous medium. *Trans Phenom Porous Media.* 1998;357-82.
- Demirel Y, Al-Ali HH, Abu-Al-Saud BA. Enhancement of convection heat-transfer in a rectangular duct. *Appl Energy.* 1999;64:441-51.
- Cheng KC, Hong, SW. Effect of tube inclination on laminar convection in uniformly heated tubes for flat-plate solar collectors. *Sol Energy.* 1972;13:363-71.
- Esfe MH, Saedodin S, Malekshah EH, Babaie, A. Mixed convection inside lid-driven cavities filled with nanofluids. *J Therm Anal Calorim.* 2019;135:813-859.
- Choi SUS, Eastman JA. Enhancing thermal conductivity of fluids with nanoparticles. 1995; No. ANL/MSD/CP-84938; CONF-951135—29. Argonne National Lab., IL.
- Lee S, Choi SUS, Li, S, Eastman JA. Measuring thermal conductivity of fluids containing oxide nanoparticles. *ASME J Heat Transfer.* 1999;121:280-9.
- Eastman JA, Choi SUS, Li S, Yu W, Thompson LJ. Anomalously increased effective thermal conductivities of ethylene glycol-based nano fluids containing copper nano-particles. *App Phys Lett.* 2001;78:718-20.
- Xuan Y, Li, Q. Heat transfer enhancement of nano-fluids. *Int J Heat Fluid Flow.* 2000;21:58-64.
- Hartmann J. Theory of the laminar flow of an electrically conductive liquid in a homogeneous magnetic field. *Mathematisk Fysiske Meddelelser,* 1937;15 (6):1-28.
- Oztop HF, Al-salem K, Pop I. MHD Mixed convection in a lid-driven cavity with corner heater. *Int J Heat Mass Transfer.* 2011;54:3494-504.
- Shirvan KM, Mamourian M, Mirzakhani S, Moghiman M. Investigation on effect of magnetic field on mixed convection heat transfer in a ventilated square cavity. *Procedia Eng.* 2015;127:1181-8.
- Jha BK, Aina B, Ajiya AT. MHD natural convection flow in a vertical parallel plate microchannel. *Ain Shams Eng J.* 2015;6(1):289-95.
- Sajjadi H, Kefayeti GR. MHD turbulent and laminar natural convection in a square cavity utilizing Lattice Boltzmann Method. *Heat Transfer Asian Res.* 2016;45(8):795-814.
- Rashidi S, Esfahani JA Maskaniyan M. Applications of magnetohydrodynamics in biological systems - a review on the numerical studies. *J magn Magn Mater.* 2017;439:358-72.
- Salman, B.H., Mohammed, H.A., Kherbeet, A. Sh., 2012. Heat transfer enhancement of nanofluids flow in in microtube with constant heat flux, *International Communications in Heat and Mass Transfer,* **39**, 1195-1204.
- Kimouche, A., Metaoui, A., Oztop, H.F., Abu-Hamdeh, N., 2017. Analysis of heat transfer of different nanofluids flow through an abrupt expansion pipe, *Applied Thermal Engineering,* 112, 965-974.
- Sheikholeslami, M., Gorji-Bandpy, M. and Ganji, D.D., 2013. Numerical investigation of MHD effects on Al<sub>2</sub>O<sub>3</sub>-water nanofluid flow and heat transfer in a semi-annulus enclosure using LMB, *Energy,* **60**, 501-510.
- Hatami, M., Nouri, R. and Ganji, D.D., 2013. Forced convection analysis for MHD Al<sub>2</sub>O<sub>3</sub>-water nanofluid flow over a horizontal plate, *Journal of Molecular Liquids,* 187, 294-301.
- Erdem, M., Varol, Y. Numerical investigation of heat transfer and flow characteristics of MHD nano-fluid forced convection in a pipe. *J Therm Anal Calorim* **139**, 3897–3909 (2020). <https://doi.org/10.1007/s10973-020-09366-8>.
- Erdem, M. 2019. [Experimental and numerical investigation of nanoparticles added magnetohydrodynamics flow](#), Ph,D Thesis, Firat University the Institute of Natural and Applied Sciences, p. 197.
- Erdem, M, Firat, M, Varol, Y. "Dairesel bir kanalda soğutma şartları altında MHD sıvı lityum akışın sayısal olarak incelenmesi". *Pamukkale Üniversitesi Mühendislik Bilimleri Dergisi* 24 (2018 ): 30-35.
- Erdem, M., & Varol, Y. (2019). Numerical investigation of PbLi17 fluid flow forced convection heating under magnetic field. *Journal of Materials and Electronic Devices,* 1(1), 41-45.
- Mishra, A., Kumar, M. Viskoz yayılımlı ve Joule ısıtmalı bir germe silindirinden geçen MHD nanoakışkan akışı üzerindeki hız ve termal kayma etkileri. *SN Appl. Sci.* **2**, 1350 (2020). <https://doi.org/10.1007/s42452-020-3156-7>
- Yousofvand R, Derakhshan S, Ghasemi K, Siavashi M. MHD transverse mixed convection and entropy generation study of electromagnetic pump including

- a nanofluid using 3D LBM simulation. *Int J Mech Sci.* 2017;133:73-90.
26. Bejan A. Convection heat transfer. John Wiley & Sons; 1995. Incorporated.
27. Zhao G, Jian Y, Chang L, Buren M. Magnetohydrodynamic flow of generalized Maxwell fluids in a rectangular micropump under an AC electric field. *J Magn Magn Mater.* 2015;387:111-17.
28. Erdem, M., Fırat, M., Varol, Y. Al<sub>2</sub>O<sub>3</sub>-Su Nanoakışkanının Manyetik Alan Altında Akış Karakteristiklerinin Sayısal Analizi. *Fırat Üniversitesi Mühendislik Bilimleri Dergisi* 33 (2021 ): 401-412